

GSD Wi-Pin



Main Features

- Used with GSD Wi-Plus & GSD Wi-Enterprise Controllers
- Monitors and Controls 1 Door
- Supports Wireless or RS485 Networks
- Up to 20000 Users (PIN) depending on controller
- 128 User Groups
- 128 Time Zones
- Challenge facility
- Slave Proximity Reade Option (Clock & Data)
- Tamper protection
- Tamper Output extendable to Intruder Panel
- Easy Programming via GSD Software
- Standard, Toggle & Manager Users
- Intruder & Fire Alarm Interface
- Interlock
- Anti-Tailgate
- Keypad Backlit
- 1 x 5amp Relays 240vac
- 3 Inputs - 1 Programmable
- 2 Outputs - 1 Programmable
- Key Programmable Features:
 - Door Timers
 - Timed Actions
 - Door Options
 - Alarm Options
 - User Groups
 - Door Groups
 - Time Zones
 - Number of PIN code Digits
 - Programming Code
- Robust Polycarbonate Housing
- Stainless Steel Keys
- Mounts onto standard Electrical Patress box
- Flush mounts using collar supplied
- Indoor/Outdoor Use IP67
- 2 Year Warranty.

Wiring Layout

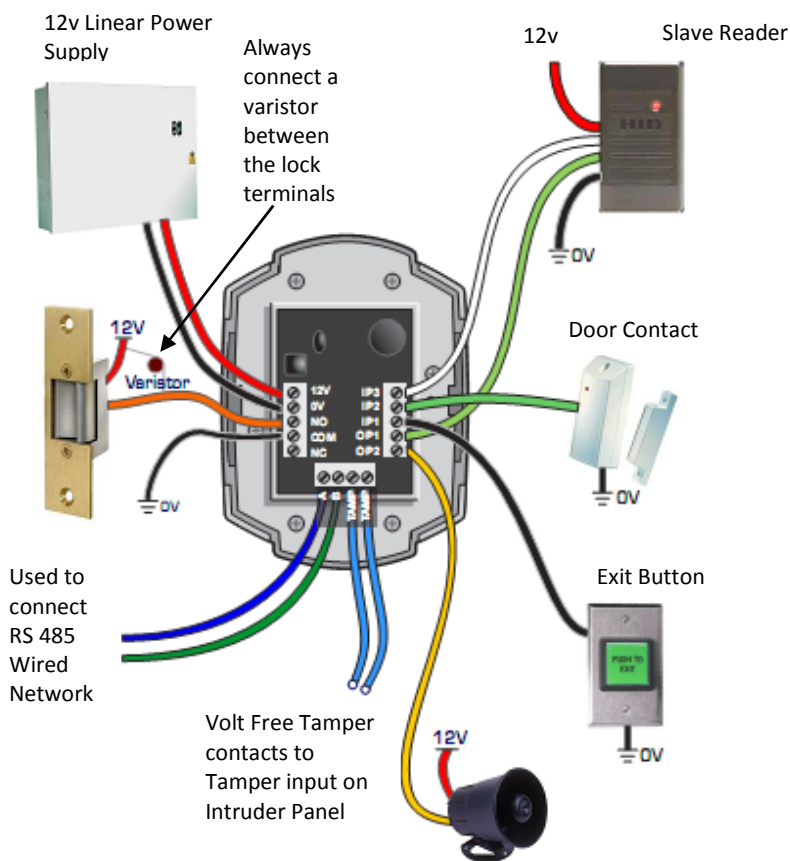

Technical Specification

- Supply 12 DC only
- Current consumption 100mA
- Current consumption with load (max) 140mA
- Relay Contact Rating 5 Amps /240V ac
- Operating Temperature -20 C to +60 C
- Moisture Resistance IP 67

Dimensions –

- Flush Mount **W.** 87mm **D.** 21mm **H.** 119mm
- Surface Mount **W.** 87mm **D.** 35mm **H.** 119mm

Ireland: Global Security Devices Ltd. S12-14 Synergy Centre, ITT Dublin, Dublin 24, Phone: +353 (1) 5242690, info@globalsecurity.ie

UK: Global Security Devices UK, Centre Court 1301 Stratford Road, Hall Green, Birmingham B28 9HH, +44(0)845 643